

# VALOR FIRES

## INSTALLER AND OWNER GUIDE

### Model 809

### Electric Heater

fitted with one of the following fascia.

Aura 2, Blenheim, Camden,  
Canberra, Debut, Flare,  
Homeflame Slimline, Otago,  
Seattle, Sonnet or Traditional.



G.C. No.EF-032-19

This guide is intended to help you install and care for your Valor Fires electric heater. Please read carefully before installing and using your heater. However, if further information is required, our

**Valor Fires Technical Helpline** will be pleased to help.

Telephone **08706 061 065**

(National call rates apply in the United Kingdom)

In the Republic of Ireland

Telephone **0044 8706 061 065**



# BAXI ● VALOR ● WONDERFIRE

**Important: Please keep your guide in a safe place for future reference**

# INSTALLER AND OWNER GUIDE

© Baxi Heating U.K. Limited 2007.

All rights reserved. No part of this publication may be reproduced in any material form (including photocopying), stored in any medium by electronic means (including in any retrieval system or database) or transmitted, in any form or by any means, whether electronic, mechanical, recording or otherwise, without the prior written permission of the copyright owner.

Applications for the copyright owner's permission to reproduce any part of this publication should be made, giving details of the proposed use, to the following address: The Company Secretary, Baxi Heating UK Limited, The Wyvern Business Park, Stanier Way, Derby, DE21 6BF.

Warning: Any person who does any unauthorised act in relation to a copyright work may be liable to criminal prosecution and civil claims for damages.

## CUSTOMER CARE

### Thank you for choosing Valor Fires

All Valor Fires heaters are designed to meet the most stringent quality, performance and safety requirements to provide our customers with many years of trouble free service. This guide aims to improve your understanding and appreciation of your new Valor Fires heater, by providing simple and informative instructions to enable you to install it and to ensure that you benefit from the excellent performance and features it has to offer.

If you require further assistance, the Valor Fires Technical Helpline will be pleased to help.

Please telephone **08706 061 065** (local rates apply in the United Kingdom). In the Republic of Ireland please telephone **0044 8706 061 065**

FOR OTHER USEFUL TELEPHONE NUMBERS SEE PAGE 15 OF THIS GUIDE

# VALOR FIRES

Valor Fires, Erdington, Birmingham B24 9QP  
[www.firesandstoves.co.uk](http://www.firesandstoves.co.uk)

Because our policy is one of constant development and improvement, details may vary slightly from those given in this publication

# INSTALLER AND OWNER GUIDE

## Safety First.

Valor Fires heaters are CE Approved and designed to meet the appropriate British Standards and Safety Marks.



## Quality and Excellence.

All Valor Fires heaters are manufactured to the highest standards of quality and excellence and are manufactured to ISO 9001.

## HANDLING AND UNPACKING

Before continuing any further with the installation of this heater please read the following:

### Important instructions.

- The lifting weight of the heater is as below:

Heat engine (kG)  
6.8

Spacer (kG)  
2.3\*

The fascia and firefront weights are not included in the heat engine weight.

\* Where models are not supplied with a spacer an optional spacer frame kit is obtainable either from the your heater supplier or direct from Valor Fires Sales. The kit is a 75mm (3 inch) spacer kit (Kit number 05801T1).

- One person should be sufficient to lift the heater. If for any reason this weight is considered too heavy then obtain assistance.
- When lifting always keep your back straight. Bend your legs and not your back.
- Avoid twisting at the waist. It is better to reposition your feet.
- Avoid upper body / top heavy bending. Always bend from the knees rather than the waist. Do not lean forward or sideways whilst handling the heater.
- Always grip with the palm of the hand. Do not use the tips of fingers for support.
- Always keep the heater as close to the body as possible. This will minimise the cantilever action.
- Use gloves to provide additional grip.
- Always use assistance if required.

# INSTALLER AND OWNER GUIDE

## SAFETY

This appliance is not intended for use by persons (including children) with reduced physical, sensory or mental capabilities, or lack of experience and knowledge, unless they have been given supervision or instruction concerning use of the appliance by a person responsible for their safety.

### Always

- **Always** install the heater in accordance with this guide. If in doubt obtain expert advice.
- **Always** make sure the electrical socket is accessible and located adjacent to, but not above the heater.
- **Always** disconnect the heater from the electrical supply before carrying out cleaning, maintenance or replacing the light bulbs.
- **Always** make sure the heater is firmly secured to prevent it from being tipped over.
- **Always** use a fireguard when young children and infirm persons can come into contact with the heater.
- **Always** use genuine Valor Fires spares.

### Never

- **Never** leave children unsupervised in a room where the heater is ON and unguarded.
- **Never** obstruct or cover the fan outlet or force items into heater openings.
- **Never** install or use the heater anywhere where water is in use, i.e. Bathrooms, Kitchens, Shower Rooms, Swimming Pools etc.
- **Never** use aerosols or steam cleaners on or around the heater.
- **Never** route the mains supply cable under carpet etc.
- **Never** install the heater close to curtains or combustible materials.
- **Never** use the heater to dry clothes etc.
- **Never** sit or stand on the heater.

# INSTALLER AND OWNER GUIDE

## FITTING THE HEATER

The installation of this heater requires a reasonable level of DIY skills. Please read this guide thoroughly before commencing installation and if in doubt, seek help from a competent person

### Do I need any tools?

1. Depending on which style of fascia you have you will need the below screwdrivers:

**A Pozidrive / Phillips / cross head** screwdriver. This should have a number 2 size end. **A flat end** screwdriver.

2. For drilling into brickwork you will need a power drill (preferably with hammer action) and appropriate size drill bit for the wall plugs supplied (See figure 2).

### Where can I fit the heater?

This heater can be fitted into fireplaces or surrounds where the following dimensions are available.

Width	390mm - 450 mm (15.35 inches - 17.72 inches)
Height	555mm - 590 mm (21.9 inches - 23.2 inches)
Depth	At least 75mm (At least 3 inches)

The heater is of a slim design and should suit most fireplace openings and fire surrounds. However, there may be some applications that require the need for a spacer where a fireplace opening or fireplace surround opening are not available i.e. a flat wall.

Some models are not supplied with a spacer frame kit. This optional spacer frame kit is obtainable either from your heater supplier or direct from Valor Fires Sales. The kit is a 75mm (3 inch) spacer kit (Kit number 05801T1).

### Important Electrical Safety

The heater must **not** be located in front of or under an electrical socket, the socket must always be accessible in order to disconnect the heater from the electrical supply for maintenance and cleaning.

#### **Important! This heater must be earthed.**

- The heater is supplied with a 3 pin 13 Amp fused re-wireable plug with 1mm<sup>2</sup> 3 core cable.
- The wires in the cable are coloured in accordance with the following code: -  
Live =Brown  
Neutral = Blue  
Earth = Green /Yellow
- The mains supply must be safely routed from the heater to an electrical socket.

# INSTALLER AND OWNER GUIDE

## Moving the Cable Guide

At the base of the heater you will find the electric cable which runs through a rectangular plastic cable guide. The cable guide is fitted into the rectangular slot on the right side of the heater. If required this can be moved and put in the rectangular slot in the centre or left hand side of the heater. For removal and fitting please see below.

## Removing the cable guide

1. Before moving the cable guide please note that the lip of the cable guide is on the outer edge of the base (See figure 1- Item 1).
2. To remove the cable guide push and lift the tab on the bottom of it and the cable guide will open (See figure 1- Item 2).
3. Lift the electric cable clear of the cable guide.
4. Hold the bottom of the cable guide close to the heater then gently pull the cable guide away from the rectangular slot (See figure 1- Item 3).

## Fitting the cable guide.

When fitting the cable guide please remember that the lip of the cable guide has to be fitted against the outer face of the base (See figure 1- Item 1).

1. Gently pinch the sides of the cable guide (See figure 1 - Item 4) and push into the desired rectangular slot.
2. Place the electrical cable into the guide and close the top.

If the mains cable is damaged, to avoid a hazard it must be replaced by a Valor Fires authorised service agent, or similarly qualified person (See the last page of this guide for useful telephone numbers).

All external wiring between the heater and the electrical supply shall comply with current IEE regulations.

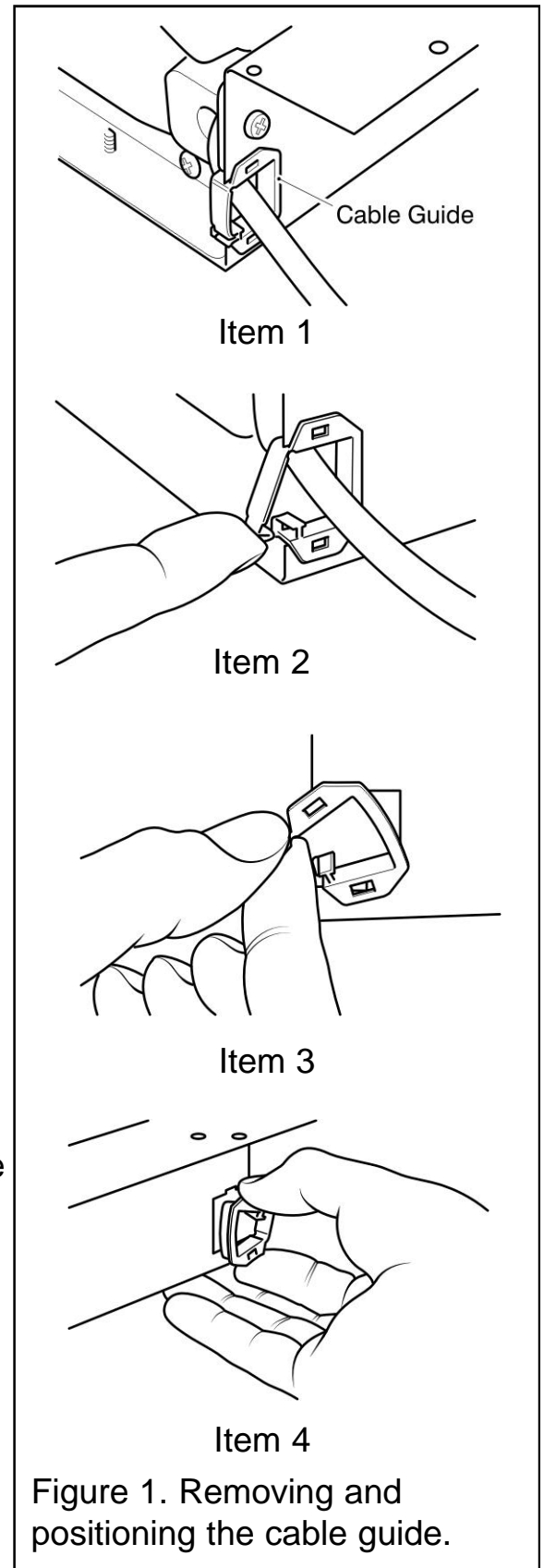

# INSTALLER AND OWNER GUIDE

## Heater Fixing

All of the fixings supplied with the heater have been identified as in figure 2.

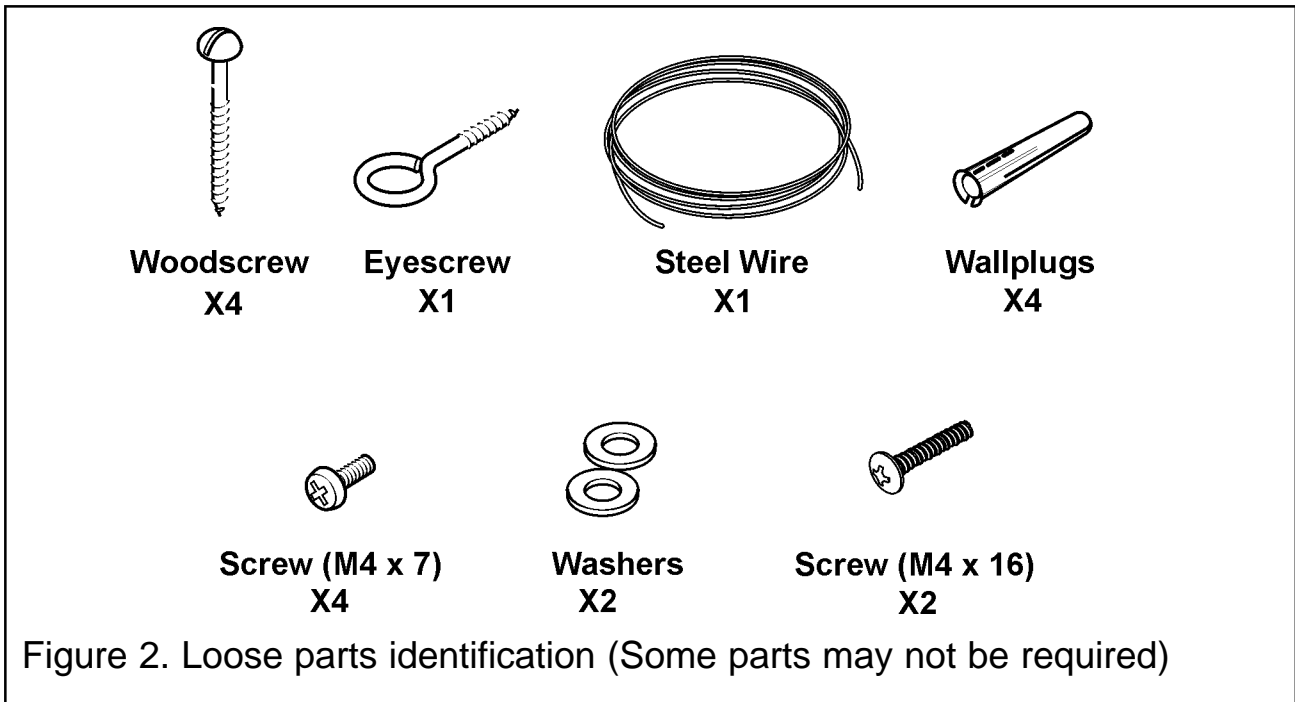

**The heater must be fixed into position to prevent it from being tipped over**

The following fixing options are available:

Screw Fixing

Wire Fixing

Spacer Frame (The spacer frame may not be supplied with the heater - see details on page 5 headed 'Where can I fit the heater?').

If fitting the heater into a fireplace or surround opening, try the heater in the opening to ensure that it will fit.

If fitting the heater onto a decorative hearth surface such as marble or tile it is advisable to protect the hearth surface. Do not drag the heater as this may scratch the hearth surface.

### Method A - Screw fixing

Note - If fixing to marble it is recommended that Method B - 'Wire fixing' is used. Drilling marble without the correct tools and experience may result in the marble cracking.

1. Place the heater into the fireplace or surround opening. Make sure that the heater is in the middle of the surround or fireplace.
2. There are two slotted holes in the top of the heater (See figure 3). Mark through the slotted holes so that their position is clear when the heater is removed.
3. Remove the heater.

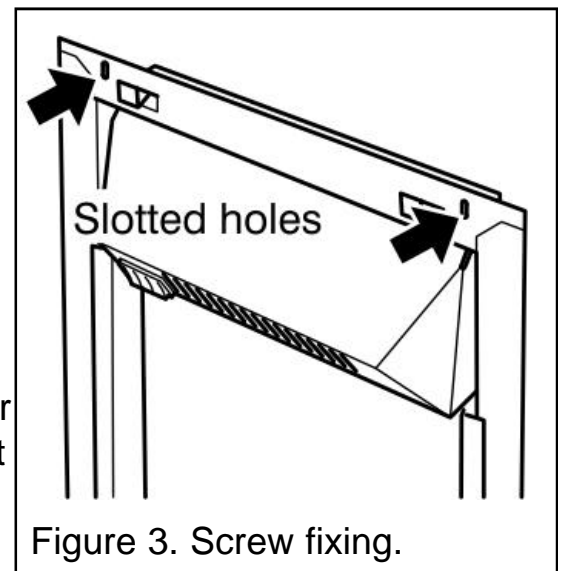

# INSTALLER AND OWNER GUIDE

4. Drill an appropriate size hole in each of the marked positions. Insert wall plugs into the drilled holes.
5. Place the heater so that the slotted holes are in line with the wall plugs in the fixing surface.
6. Screw and secure the heater with two woodscrews (See figure 2).

## Method B - Wire Fix

This method of fixing needs a fireplace opening and is recommended when fixing the heater to a marble surround or where the wall or brickwork is in poor condition.

1. The fixing kit supplied with the heater includes a steel wire and eyescrew (See figure 2). These can be used to secure the heater to the back of a fireplace opening.
2. Mark the eyescrew position on the centre line at the back of the fireplace opening and at a height of 533-560mm (21 inches - 22 inches) (See figure 4).
3. Drill an appropriate size hole in the marked position.

4. Insert a wall plug into the drilled hole.
5. Screw the eyescrew into the wall plug.
6. Position the heater in front of the fireplace opening.

7. At the top of the heater there are four small holes, two each side of the heater (See figure 5- Item 1). From the front of the heater, thread about 50mm (2 inches) of the steel wire into the inside small hole on the left side of the heater (See figure 5 - item 2).

8. Thread the other end of the wire through the remaining small hole on the left hand side of the heater. Continue to push the wire through this hole until there is only a small loop of wire at the front of the heater (See figure 5 - item 3).

9. At the back of the heater there will be a long piece and a short piece of wire coming through the two holes. Hold the short piece and give the long piece a gentle tug. This will secure the steel wire. Take the long piece and thread this through the eyescrew in the back of the fireplace opening (See figure 5 - item 4).

10. From the back of the heater thread the long piece of steel wire through the outer small hole on the right hand side of the heater (See figure 5 - item 5).

11. Locate the heater in the fireplace opening, then from the front of the heater, gently pull the steel wire on the right hand side to gather up the excess until the heater is secure. Thread the wire through the remaining small hole to lock the wire and heater in place (See figure 5 - item 6).

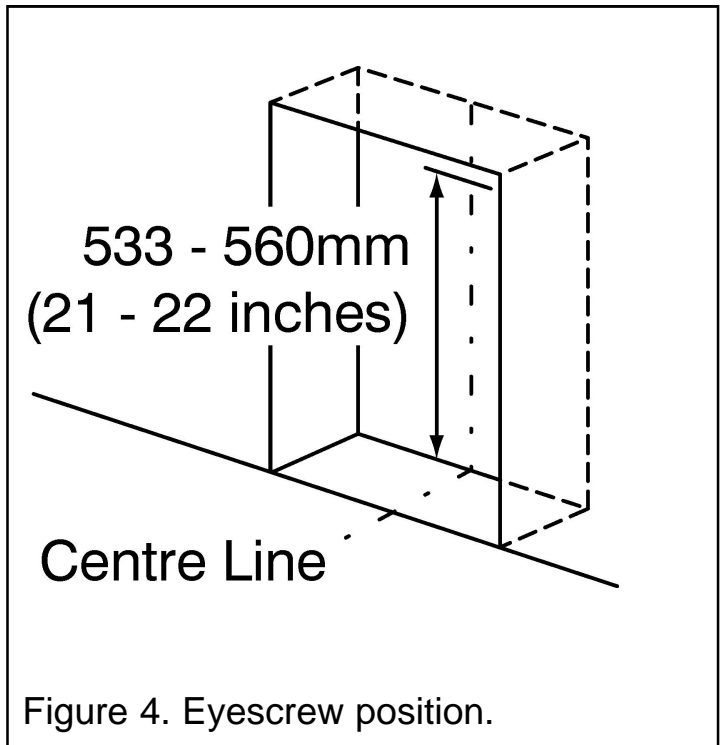

Figure 4. Eyescrew position.



# INSTALLER AND OWNER GUIDE

## Method C - Spacer Frame

The spacer frame is for use during installations where a chimney recess or rebated fire surround are not available. For your safety the frame and heater must be securely fixed to the rear wall.

1. Position the spacer frame against the wall. Ensure that the spacer frame is central to the fireplace.
2. The top rear flange of the spacer frame has two screw locations. Mark the positions of the two screw locations on the rear wall (See figure 6).
3. Remove the spacer frame from the fireplace and place away from the work area.
4. Drill the screw locations using a no. 12 masonry drill bit.
5. Insert the two wall plugs provided into the holes
6. Insert a wood screw into each hole and screw in until there is approximately 6mm of screw protruding from the wall.

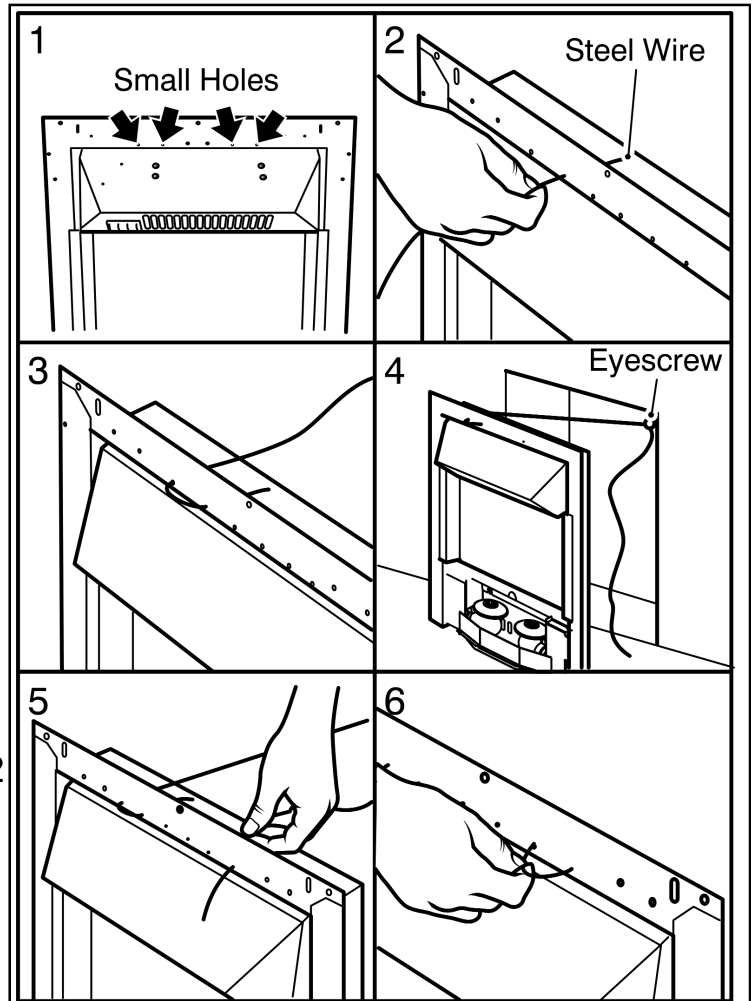

Figure 5. Steel wire fixing (The fuel effect may differ from that shown)

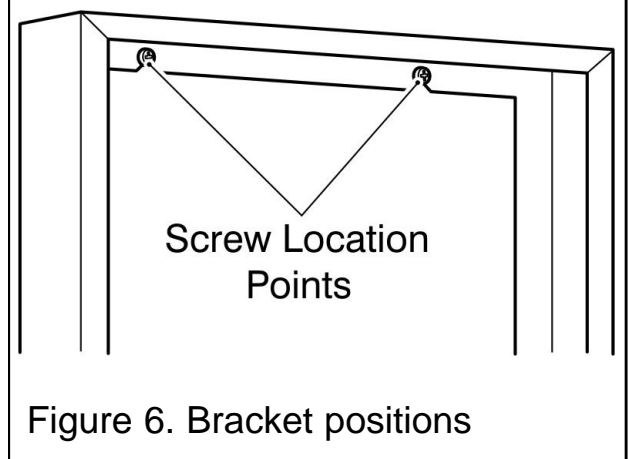
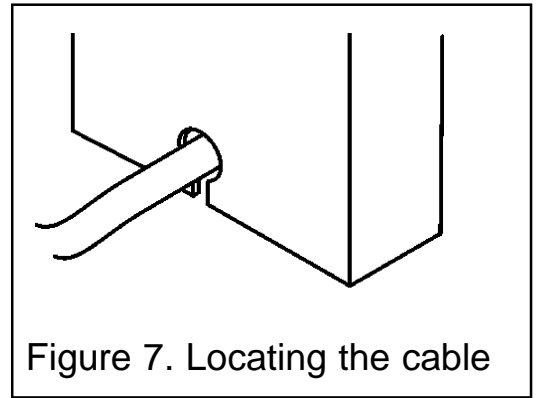

Figure 6. Bracket positions

# INSTALLER AND OWNER GUIDE

## Preparing the heater for installation.

1. Using the four screws provided in the spacer frame kit, fix the heater to the spacer frame.
2. There is a supply cable slot on both sides of the spacer frame. It is located at the base. Decide which side to pass the supply cable through.
3. Position the supply cable in the spacer frame slot (See figure 7).



## Locating the spinners.

- It is possible that during transit the metal disks or 'spinners' located above the bulbs may have become dislodged. This will cause a poor flicker flame effect. Relocate the spinners centrally on their pins for best effect.

## Fitting the firefronts and fascia

### Important notes.

- The coal pieces supplied are a natural material. Occasionally it will be necessary to reduce the size of the coal pieces. To do this place them inside a plastic bag, place on a suitable hard surface and tap gently with a small hammer or similar tool.
- **The pebbles and coals are for decorative purposes only. There is a choke risk to young children. Make sure they cannot gain access to them.**

## Fitting the fuel support

### Debut and Flare models.

1. The fuel support must be fitted to the heater before fitting the fascia assembly. To do this, align the four holes in the fuel support with those on the heater (See figure 8). Secure with the four screws supplied.

### Aura 2, Camden, Otago and Seattle models.

1. The fuel support is already assembled to the firefront.

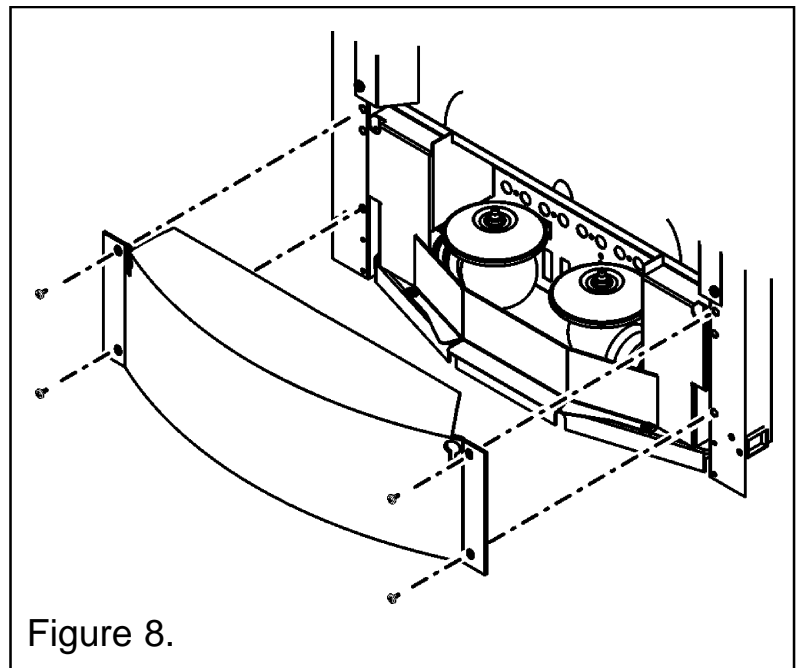

# INSTALLER AND OWNER GUIDE

## Sonnet, Blenheim, Canberra, Homeflame Slimline and Traditional heaters.

1. The fuel support must be secured to the casting before fitting to the heater. To do this, locate the fuel support on the casting and secure with the screws and washers supplied (See figure 9).

### Fitting the fascia and firefront / casting assembly.

#### Sonnet, Blenheim, Canberra, Homeflame Slimline & Traditional models.

- Position the four magnets onto the rear of the fascia assembly (See figure 9) and locate the fascia on to the heater.
- Fit the two casting hanging screws (Supplied) to the casting (See figure 10). Locate the casting hanging screws into the slots in the heater (See figure 11). It may be necessary to adjust the length of the hanging screws to obtain a snug fit. Position the ash pan cover under the casting.

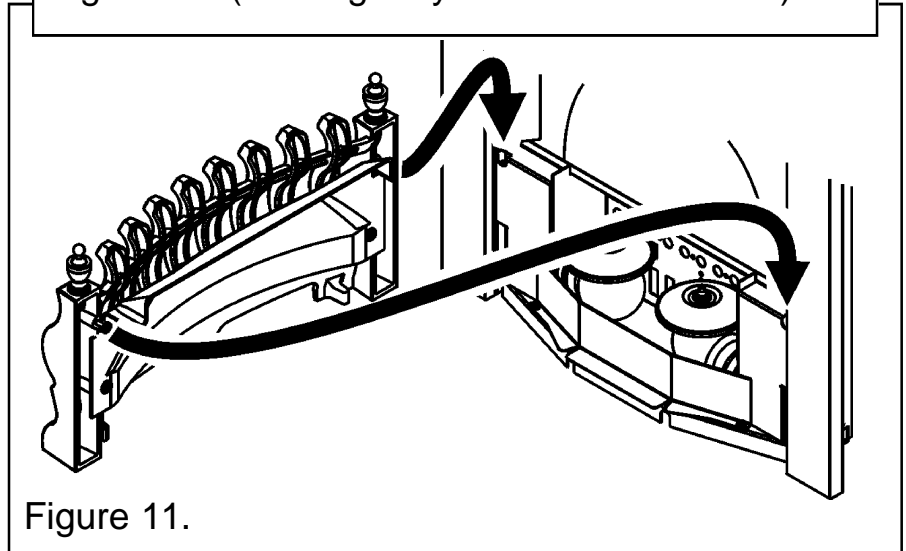
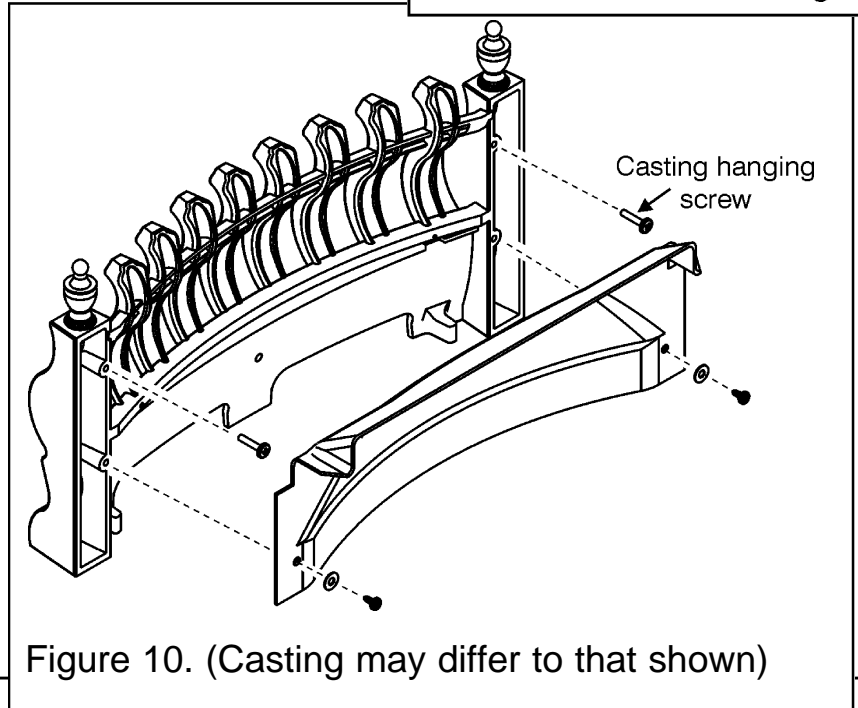
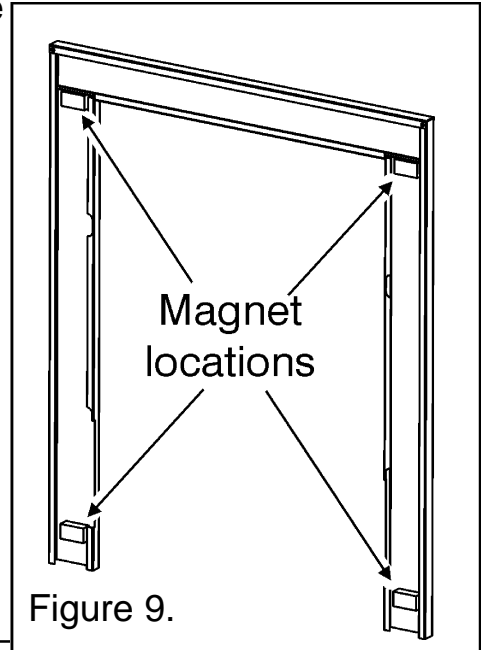

# INSTALLER AND OWNER GUIDE

## **Debut and Flare models.**

- Position the four magnets onto the rear of the fascia assembly (See figure 9) and locate the fascia on to the heater.
- Fit the two casting hanging screws (Supplied) to the casting (See figure 10). Locate the casting hanging screws into the key hole slots in the fuel support (See figure 12). It may be necessary to adjust the length of the hanging screws to obtain a snug fit. Position the ash pan cover under the casting.

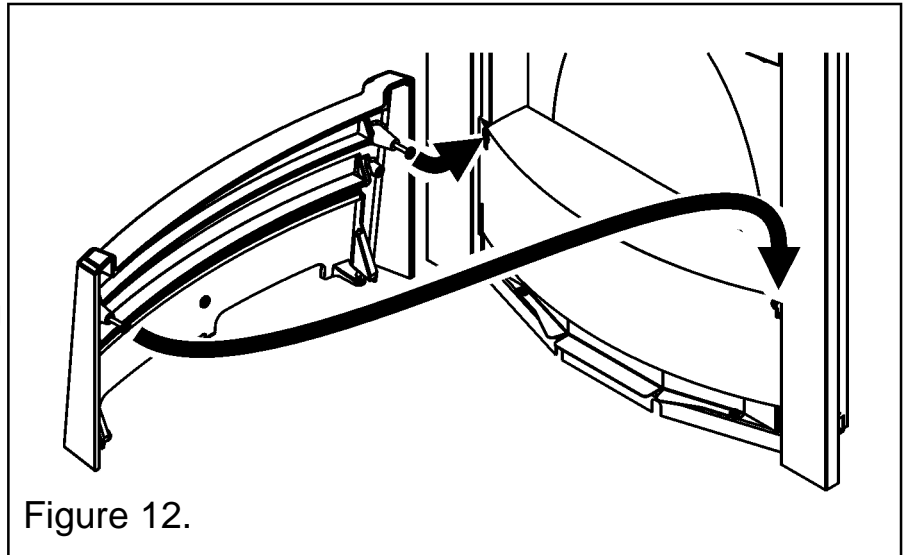

Figure 12.

## **Aura 2, Otago, Camden and Seattle models.**

- Align the four holes in the firefront assembly with those on the heater (See figure 13). Secure with the four screws supplied.
- Position the four magnets onto the rear of the fascia assembly (See figure 9) and locate the fascia on to the heater.

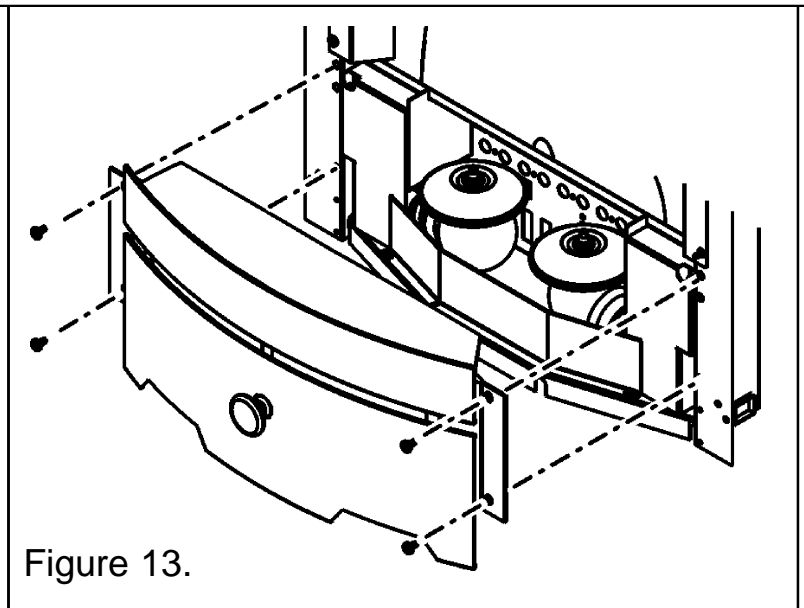

Figure 13.

# INSTALLER AND OWNER GUIDE

## USING THE HEATER

### Important Safety.

Never cover the heater or obstruct the openings at the base of the heater, this could cause overheating and consequent risk of fire.

### What are the three switches for?

The heater is operated by three switches located below the hood on the left hand side of the heater.

Switch 1 = 

Main On - Off. (In the 'ON' position, only the flame effect operates)

Switch 2 = 

1kW fan heat setting and flame effect. (Switch 1 needs to be in the 'ON' position to enable switch 2 to operate).

Switch 3 = 

2kW fan heat setting and flame effect. (Switch 2 needs to be in the 'ON' position to enable switch 3 to operate).

## CLEANING AND MAINTAINING THE HEATER

### How do I Clean my heater?

The heater fascia, spacer frame and plastic parts need only to be wiped clean with a dry soft cloth, do not use polishes or abrasive materials. Heaters with fascia, other than brass, may have finger prints on the fascia surface. These can be removed by applying a small amount of 'baby oil' to a lint free non-abrasive cloth and wiping the surface. Use a clean cloth to remove the oil.

### I have a problem with my heater!

#### Important Safety

**Before undertaking maintenance or replacing the light bulb(s) always disconnect the heater from the electricity supply by removing the 3 pin plug and allowing the heater to cool.**

#### 1. My heater is on but there is no light / low light.

This is possibly a light bulb failure. Remove the light bulb(s) as below and check it / them in a table lamp that is known to work. If it / they do not work in the table lamp then replace it / them as follows.

The light bulb(s) fitted to this heater are 60Watt fireflame (Red) bayonet type, but due to the indeterminate life span and ease of replacement, it is specifically excluded from

# INSTALLER AND OWNER GUIDE

the guarantee.

## **To replace the light bulb(s) on Sonnet, Blenheim, Canberra, Homeflame Slimline and Traditional heaters.**

1. To gain access to the light bulb(s), remove the loose coals / pebbles from the fuel support.
2. Remove the firefront casting and ash pan.
3. Push and turn the bulb(s) in an anti-clockwise direction.
5. Replace the light bulb with a 60Watt fireflame (Red) bayonet type bulb.
6. Locate the lower firefront casting onto the product. The two screws on the rear of the firefront casting locate into the two slots in the heater (See figure 11).
7. Fit the ash pan into place.
8. Place the coals / pebbles back on top of the fuel support.

## **To replace the light bulb(s) on Debut & Flare heaters.**

1. To gain access to the light bulb(s), remove the loose coals / pebbles from the fuel support.
2. Remove the firefront casting and ash pan.
3. Remove the fascia in the reverse order to that shown in figure 9.
4. Push and turn the bulb(s) in an anti-clockwise direction.
5. Replace the light bulb with a 60Watt fireflame (Red) bayonet type bulb.
6. Fit the fascia (See figures 9).
7. Locate the lower firefront casting onto the product. The two screws on the rear of the firefront casting locate into the two keyhole slots in the plastic fuel support.
8. Fit the ash pan into place.
9. Place the coals / pebbles back on top of the fuel support.

## **To replace the light bulb(s) on Aura, Aura 2, Otago and Camden heaters.**

1. To gain access to the light bulb(s), remove the loose coals / pebbles from the fuel support.
2. Remove the fascia in the reverse order to that shown in figure 9.
3. Unscrew and remove the firefront assembly.
4. Push and turn the bulb(s) in an anti-clockwise direction.
5. Replace the light bulb with a 60Watt fireflame (Red) bayonet type bulb.
6. Fit the firefront assembly back into place using the four screws previously removed.
7. Fit the fascia (See figures 9).
8. Place the coals / pebbles back on top of the fuel support.

# INSTALLER AND OWNER GUIDE

## **2. My heater is on, there is light, but there is no flicker effect or the flicker effect is on one side of the heater only.**

This is possibly a 'spinner' that has stuck. The 'spinners' are metal disks that are located above the light bulbs. To access the spinners follow the instructions given for replacing the light bulb(s) on the previous page, but do not touch the light bulb(s). Gently rotate the appropriate 'spinner' by hand. This should get it / them working again.

## **3. My heater is on but there is no light or heat.**

The first thing to do is check the wall socket. To do this plug in a known working appliance. If the appliance you have plugged in works then there is a good chance that the problem lies with the 13 Amp fuse in the heater plug. If either fuse or socket is suspected, have them checked by an electrician.

## **4. My heater is on but there is no heat.**

A cut out device is fitted to the heater to prevent damage due to over heating. If it operates due to an obstruction in the airflow, the heater must be turned off and allowed to cool for 15 minutes and the obstruction removed before restarting.

## **5. I have a problem that is different to those in the previous examples 1- 3.**

Below is a list of Useful Telephone numbers. See also the 'Warranty and Service' section of this guide.

For general advice about your heater:

**VALOR FIRES TECHNICAL HELPLINE 08706 061 065.**

To report faults or arrange for your heater to be serviced:

**VALOR FIRES SERVICE 08706 090 081.**

For sales or product information:

**VALOR FIRES SALES 08706 061 067.**

CALLERS IN THE REPUBLIC OF IRELAND

**Call 0044 8706 061 065**

# INSTALLER AND OWNER GUIDE

For spares inquiries

**Spare parts are available nationwide via the 'interpart stockist network'. For your local stockist consult Yellow pages under 'Central Heating'.**

When ordering spare parts please have the below information available. This will help us to deal with your call quicker and avoid you having to make a second call.

- Your Post Code
- Type of Heater (Electric or gas)
- Model, Name and serial number (This information can be found on a small label attached to the top of the heater and should also have been recorded on the last page of this guide. To see the label you will have to remove the fascia trim (See figure 14 for label location). It may be necessary to remove the firefront casting before pulling the fascia clear of the heater.
- The fault, problem or request.

## 8. ENVIRONMENT

### **Environmental Protection.**

Waste electrical products should not be disposed of with household waste. Please recycle where facilities exist. Check with your local authority or retailer for recycling advice.

### **What should I do when I'm ready to dispose of my heater?**



The plug should be removed from the mains cable and the mains cable cut from the heater. These should be disposed of with the heater.



# INSTALLER AND OWNER GUIDE

## 9. WARRANTY AND SERVICE

### Information for the customer

#### Standard Warranty Terms & Conditions

The warranty is for 12 months subject to contract.

In the United Kingdom servicing can be carried out either by a **heateam** service engineer or a CORGI registered installer.

You must register your heater with **heateam**, the service division of Baxi Heating UK Limited, either by completing and returning the registration card or calling our free telephone registration line on **0800 032 72 44**.

#### Our promise to you

If you experience a fault with your new heater, we aim to provide a safe and high quality repair service supported by our dedicated national network of highly skilled engineers. Nothing in this warranty will affect your statutory rights.

What you need to do if you experience a problem with the operation of the heater;

Read the “Cleaning and maintaining the heater” section of this guide. If the problem cannot be resolved simply call our service division **heateam** on **08706 090 081** to book an engineer visit or for any general advice that you may need. Our contact centre is open Monday to Friday 8am – 6pm, weekends and Bank Holidays 8.30am – 2pm, excluding Christmas Day and New Years day.

When calling **heateam**, it would be helpful if you could have the following information to hand:-

1. Heater serial number
2. Heater brand and model number
3. Date of installation
4. Proof of purchase (If you do not have the heater serial number)

Note; details 1 – 3 can be found on the last page of this guide.

#### What this warranty covers

Free of charge repair or replacement of components found to be of faulty manufacture.

Free of charge replacement of the complete unit providing the failure is related to a manufacturing fault that cannot be repaired or is uneconomic to repair.

# INSTALLER AND OWNER GUIDE

## **What this warranty does not cover**

Repairs to heaters which haven't been installed properly and as set out in this guide.

Faults caused by inadequate supply of electricity.

Reimbursement of any third party repair or replacement costs that we haven't been told about or agreed with you in advance.

Compensation or consequential losses (e.g. loss of earnings, business losses, stress and inconvenience) arising from a production breakdown, including repair delays caused by factors outside our reasonable control.

# INSTALLER AND OWNER GUIDE

Model

Serial number (Can be found on the information label - See figure 14)

A LABEL CONTAINING THE SERIAL NUMBER MAY HAVE BEEN PLACED INSIDE THIS BOX.

Fascia name (Block Capitals)

Fascia code - Can be found close to the information label (Block Capitals)

A LABEL CONTAINING THE FASCIA CODE MAY HAVE BEEN PLACED INSIDE THIS BOX.

Brand (Please tick)

Baxi

Valor

Wonderfire      Other.....

Date of Installation

D    D    M    M    Y    Y

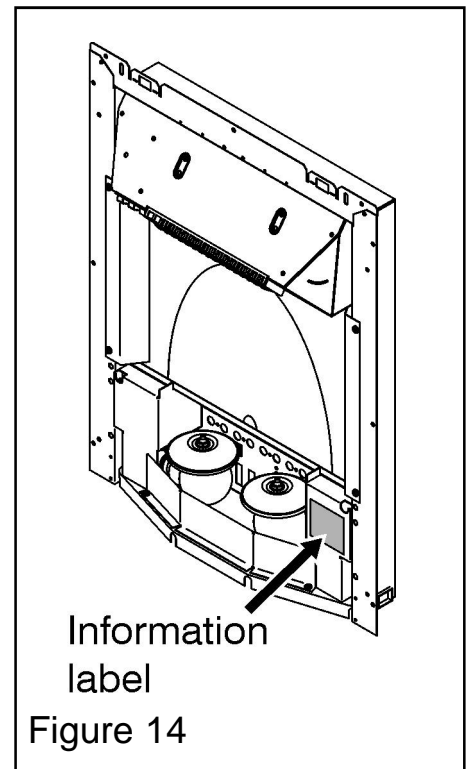

VALOR FIRES